

Timber Frame Construction

ARCHITECTURALLY EXPOSED TIMBER

By Ben Brungaber and Jim DeStefano



Figure 1: Traditional Timber Framing

Timber frame construction, consisting of heavy timbers joined with interlocking connections, dominated construction in Europe and Asia for over 2000 years. But nowhere did it flourish as it did in America. The demand for new buildings and the virtually unlimited forests in colonial America drove the technology of timber framing to new heights. America became a melting pot of English, Dutch and German styles of timber framing. Unleashed from the restrictions of medieval European guilds, early American timber framers were free to innovate more efficient methods of laying out and cutting timber joints.

Two significant technological developments in the mid nineteenth century resulted in the decline of timber frame construction. The circular sawmill, powered first by water and later by steam, made producing small and uniform dimension lumber very efficient. The wire nail machine dramatically reduced the cost of the iron nails that were previously produced individually by blacksmiths.

With dimension lumber and inexpensive common nails now readily available, light frame wood construction soon replaced timber framing. Early light frame wood construction was called “balloon construction” because the structures appeared so light and fragile. Carpenters with far less skill than that required to build a timber frame structure could build balloon frame structures quickly. By 1900, timber frame residential construction had all but died out and, by WWII, was even replaced in barns.

The Revival of Timber Framing

Timber frame construction has experienced a rebirth. It started in New England in the 1970's with a group of young carpenters exploring alternative building technologies. They had become disenchanted with the sterile nature of mass-produced stick frame houses, and were drawn to the handcrafted character of timber frame construction. The timber frame revivalists built frames that emulated and reproduced the forms and joinery of early American frames. Some of these pioneers even scorned the use of power tools and worked exclusively with hand tools.

Over the next decade, the industry matured as timber framers became more proficient at the craft and learned more about the traditional technology. The *Timber Framers' Guild of North America* formed to share and disseminate information about the craft. Power tools were developed and adapted from other countries for cutting timber frame joints. But timber framing remained a small backwoods

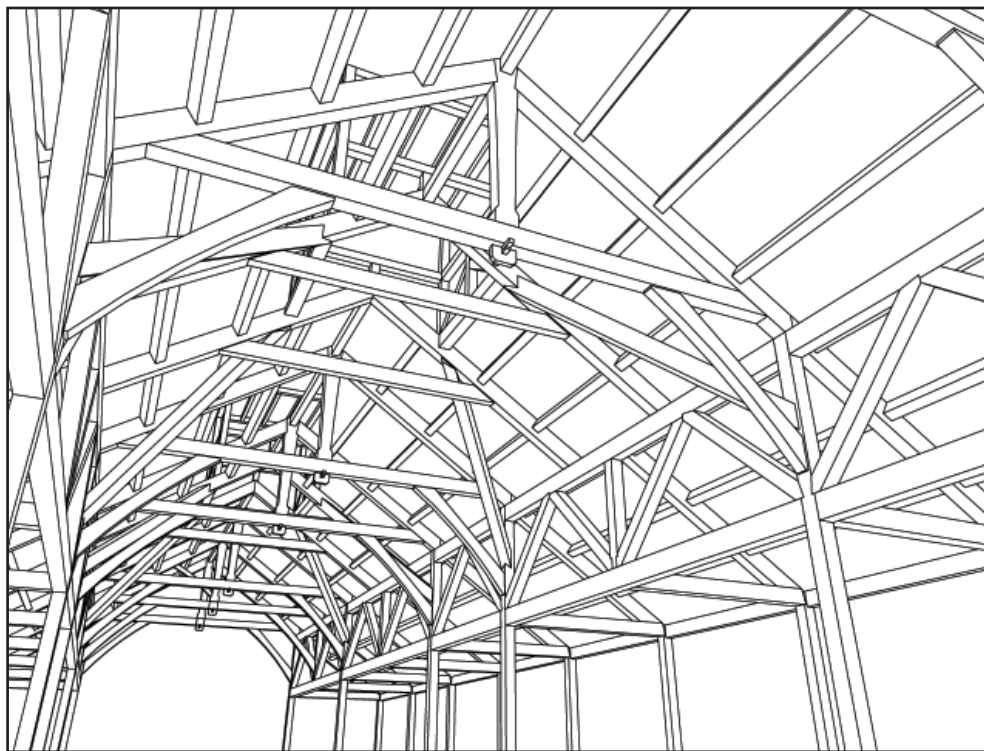

Figure 2: 3D CAD drawings are used for design and shop drawings

industry, serving a few select clients who appreciated handcrafted buildings.

In 1989, *This Old House*® rebuilt a timber frame barn in Concord, MA on national TV. The demand for timber frame structures exploded almost overnight, and the industry has not been the same since. Timber framing has become a mainstream building technology, and the small backwoods timber framers have grown into large businesses building commercial and public buildings using high-tech design and fabrication methods.



Figure 3: Computer controlled timber cutting machine

Timber Framing Goes High-Tech

Today, most timber frames are engineered structures. Many of the established timber framing companies now use computer-generated 3-D shop drawings when describing their frames. These drawings are particularly useful for both defining their scope of work and for helping clients to visualize how the

finished timber frames will look.

The colonists who built the first American timber frames would have been thrilled simply to have our electric handsaws and drills at their disposal. These tools are what modern timber framers used first, but they are just powered versions of venerable tools that the original framers would have recognized. Over the last twenty years, there has been tremendous progress in some very specialized and powerful new tools. There are nearly a dozen manufacturers, world-wide, of heavy stationary saw platforms that can cut a tenon in a single pass.

But what has really revolutionized the fabrication of timber frame structures is the numerically-controlled timber cutting machines that can do a lot of the tedious, yet critical, work in crafting timbers. The German-manufactured Hundegger timber cutter has become the tool of choice among the established timber frame companies.

With a Hundegger, the automated fabrication of timbers flows seamlessly from the 3-D shop drawings. This huge upgrade in tool sophistication means that much of the framers' time with tape measures, squares and pencils has been translated into time in front of a terminal, tweaking the cutting instructions. The big timber cutters also do an exquisitely accurate job of removing much of the wood in traditional joinery designs.

There is still a lot of handwork and craftsmanship left to do, though. Even modern timber framers still use chisels to



Figure 4: Cranes are used to erect frames

square out housings – although they are likely to be exquisite examples of these ancient tools, carefully made in Japan. In this shrinking world market, American timber framers are also likely to use power chamfer planers made in Spain, stout French chisels, and heavy power planers made in Germany. Carvings, embellishments, and shop finishes are still crafted with hand tools.

Timber Frame Raising

Most people have a very romantic image of a timber frame raising (erection). It calls to mind images of an Amish barn being raised and sheathed in a single day by hundreds of neighbors while the women cook and sew quilts and the children run underfoot. American hand raisings are actually infrequent, and are generally limited to projects where the raising becomes an event to celebrate the construction.

Timber frames are generally raised with a small crew and a crane, much the way a structural steel building is erected. Tapered hardwood pegs are used instead of high-strength bolts and sharp chisels are used for field adjustments rather than cutting torches.



Figure 5: Roof framing has been assembled on the ground

Most modern timber frames are clad with Structural Insulated Panels (SIP) that are installed immediately following the frame raising. SIP's create a very energy efficient building envelope and allow the timber frame to be completely exposed to view on the inside of the building.

Even using cranes to raise timber frames, it is still customary to celebrate the topping out of a frame with an evergreen bough secured to the ridge pole, a tradition that has endured over 1,000 years.

Timber Joinery

A structure is only as strong as its connections. This is especially true with timber frame structures. The joinery design and detailing is often the most challenging aspect of engineering a timber frame.



Figure 6: Modern timber joinery

Mortise and tenon joints are most commonly used to connect timbers. Hardwood pegs hold the joints together but are seldom relied on to transfer loads. The safe load on a 1-inch peg in shear is approximately 1 kip, making a peg a poor substitute for a bolt.

The challenge of engineering a timber joint is to configure the geometry of the joint so that structural forces are transferred in bearing rather than through fasteners. Traditional timber joints rely innately on removing material from one member, in order to support another. This accentuates the art of compromise in designing these joints, creating a joint that is strong enough

to support one timber while not unduly weakening the other. Consideration must also be given to how the joint's geometry will change when the timbers dry.

There are still circumstances where architectural constraints or large reactions mandate the use of steel hardware and fasteners. While there are a variety of proprietary concealed connectors that can be used, the hardware is more commonly custom designed and fabricated. Considerable ingenuity is sometimes needed to engineer a viable connection with no visible parts.

Modern timber joinery has evolved with the aid of engineering knowledge and automated fabricating machinery. Timber framers no longer limit themselves to using traditional joints based on archeological analysis of historic structures. By combining elements of traditional European-based timber frames, with even more ancient techniques from the Far East, modern timber framers have been able to generate a remarkably rich new set of joinery designs and details. Perhaps the biggest single component of this inclusive attitude has been the wide acceptance of the through-spline joint. Replacing a pair of tenons (as brought over from European examples) pegged into opposite faces of a supporting post, the through-spline joint (as found in many Asian frames) offers a lot of advantages to the modern timber framer.

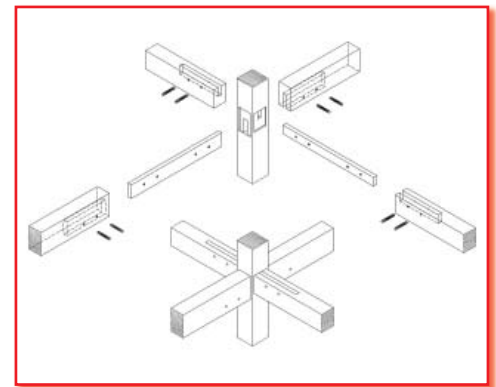

Figure 7: Spline joint detail

Tension is usually the most challenging loading for timber connection designers. A big advantage of through-splined connections is that all the pegs are inducing parallel-to-the-grain forces when the joint is loaded in tension. This makes the same pegs both stronger and stiffer, while the post size no longer limits end distances beyond the pegs with necessarily-short tenons, allowing the designers to use more pegs than would fit into any reasonable post. If the spline is not even pegged to the post, less damage is being done to the post; it is no longer being pulled apart by the opposing tenons.



Figure 8: Quartered logs used for columns

Emerging Trends in Timber Framing

A currently popular way to celebrate timber's natural root sources in structures is to use "simple" peeled logs in various ways. A log can serve quite well as beam or post, while remaining clearly organic. Including the non-prismatic, chaotic shapes found in natural logs within the regimented structures of planed and numerically cut timbers can add a lot of interest; along with cost and complexity. Some clients ask that trees cut to clear their site be included in their frames – either as sawn and planed timbers or as much rougher rustic log elements.

Immense, central focus logs can establish an atmosphere for an entire building (see the March 2004 Structure Magazine cover photo). Smaller logs can be expanded into larger posts by quartering them and leaving the pieces spaced apart, so as to reveal how the tree grew. The gaps between the post components can also provide a fun place for indirect lighting.

Solid logs, used as posts, can also be detailed to further stress their natural state by including the trunk swelling at the root ball. This



Figure 9: Curved timbers have been cut from larger straight timbers

can make the log seem to be growing from the floor. This elegant detail, especially popular in western lodges, also complicates the acquisition, transportation, and fabrication processes.

Curved timbers, another recent popular timber structure detail, can be fraught with structural and aesthetic concerns. Architects seem to love them, and computers have made them scarily easy to draw. Mother Nature, on the other hand, generally grows trees with largely straight grain. While

large and long curved timbers can be cut from even larger straight grain material and make decent trim, their structural applications should be viewed with some suspicion. There are really only three ways to get a curved timber to behave structurally in any predictable way: use glue-laminated timbers of varying degrees of elaboration (see the cover photo for a prime example), find naturally bent trees from which to saw the curved timbers, or contrive to bend straight solid timbers through combinations of heat, chemistry, and force.

Working with Timber Framers

Structural engineers working with timber frames and timber framers can find each to be both exhilarating and exasperating. The thrill can come from working with structures that are sought out by the end users and exposed to view; rather than hidden as quickly as possible. The frustrations of working with timber frames can be legion, and include: working without the net of established and widely known formal code coverage, working with clients and architects who really care what a structure *looks* like—while still paying attention to costs, and working with timber framers who can be convinced that they know a lot more about their structures (and how they behave) than does a structural engineer.

As with many fields, working with the biggest and most established timber frame companies

can do wonders for the engineer working with the methodology for the first time. Even the bigger design/build timber frame companies have not been around so long as to become insufferable in the certainty of their experience. Any timber framing company that has been involved with any meaningful projects has learned to deal with the requirements and protocols followed by engineers charged with protecting the good of our society. While a few timber frame companies have in-house engineers, most have established a relationship with a structural engineering firm and are accustomed to producing engineered shop drawings.

One of the unique characteristics of timber framers is their passion for their work. You won't find many timber framers driving brand new pick-up trucks. They do what they do because they love it.

Aesthetics of Timber Framing

Timber frame construction has become popular for one reason—people love the look. For all the dramatic progress that has been made in the technology of fabricating, erecting, and equipping timber framed buildings, most people are drawn to timber framing by their appreciation of exposed and celebrated heavy timber structures. Besides the "warmth" of the exposed timber, the owners seem most to love the expressed craftsmanship of the traditional joinery methods.

While glue-laminated timber structures with exposed bolts and gusset plate connections have a very industrial look, timber frame structures with traditional style joinery more closely resemble the craftsmanship of fine furniture.

As structural engineers, the vast majority of structural frames that we design are concealed from view behind architectural finishes. With timber frame structures, the structural design becomes the focal architectural element of the building. There is something very exciting and gratifying about designing an artful structure that is expressed and appreciated in the final building. ■

*R.L. "Ben" Brungraber, Ph.D., P.E.
is the director of engineering at
Benson Woodworking Company, Inc.
in Walpole, NH.*

*Jim DeStefano, P.E. is senior partner with
DeStefano Associates in Fairfield, CT.*